

## JA-10 Fixed Angle Rotor

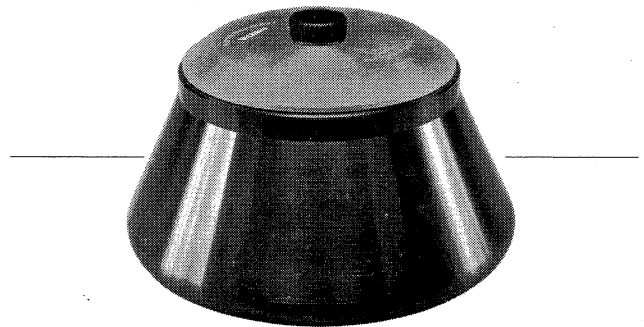

Used In Beckman Coulter  
J2, J6, and  
Avanti® J Series Centrifuges



## SAFETY NOTICE

This safety notice summarizes information basic to the safe use of the rotor described in this manual. The international symbol displayed above is a reminder to the user that all safety instructions should be read and understood before operation or maintenance of this equipment is attempted. When you see the symbol on other pages throughout this publication, pay special attention to the specific safety information presented. Observance of safety precautions will also help to avoid actions that could damage or adversely affect the performance of the rotor. This rotor was developed, manufactured, and tested for safety and reliability as part of a Beckman Coulter centrifuge/rotor system. Its safety or reliability cannot be assured if used in a centrifuge not of Beckman Coulter's manufacture or in a Beckman Coulter centrifuge that has been modified without Beckman Coulter's approval.



Handle body fluids with care because they can transmit disease. No known test offers complete assurance that such fluids are free of micro-organisms. Some of the most virulent—Hepatitis (B and C) viruses, HIV (I–V), atypical mycobacteria, and certain systemic fungi—further emphasize the need for aerosol protection. Handle other infectious samples according to good laboratory procedures and methods to prevent spread of disease. Because spills may generate aerosols, observe proper safety precautions for aerosol containment. Do not run toxic, pathogenic, or radioactive materials in this rotor without taking appropriate safety precautions. Biosafe containment should be used when Risk Group II materials (as identified in the World Health Organization *Laboratory Biosafety Manual*) are handled; materials of a higher group require more than one level of protection.



The rotor and accessories are not designed for use with materials capable of developing flammable or explosive vapors. Do not centrifuge such materials in nor handle or store them near the centrifuge.



Although rotor components and accessories made by other manufacturers may fit in the JA-10 rotor, their safety in this rotor cannot be ascertained by Beckman Coulter. Use of other manufacturers' components or accessories in the JA-10 rotor may void the rotor warranty and should be prohibited by your laboratory safety officer. Only the components and accessories listed in this publication should be used in this rotor.



Do not run an empty rotor. Place filled tubes in at least two opposing cavities. Make sure that filled containers are loaded symmetrically into the rotor and that opposing tubes are filled to the same level with liquid of the same density.



If disassembly reveals evidence of leakage, you should assume that some fluid escaped the rotor. Apply appropriate decontamination procedures to the centrifuge and accessories.



Never exceed the maximum rated speed of the rotor and labware in use. Refer to the section on RUN SPEEDS.



Do not use sharp tools on the rotor that could cause scratches in the rotor surface. Corrosion begins in scratches and may open fissures in the rotor with continued use.

## JA-10 FIXED ANGLE ROTOR

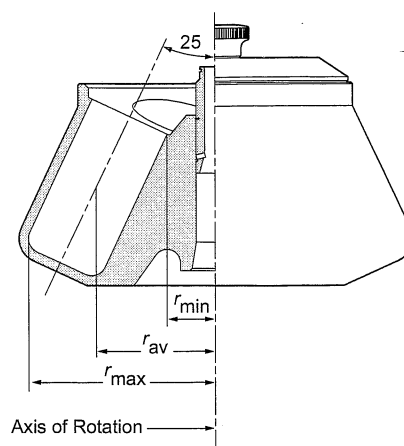

## SPECIFICATIONS

Maximum speed	10 000 rpm
Critical speed range*	600 to 800 rpm
Maximum solution density	1.2 g/mL
Maximum allowable imbalance of opposing loads	10 grams
Relative Centrifugal Field† at maximum speed	
At $r_{\max}$ (158 mm)	17 700 × g
At $r_{\text{av}}$ (98 mm)	11 000 × g
At $r_{\min}$ (38 mm)	4 260 × g
$k$ factor at maximum speed	3610
Number of bottle cavities	6
Available bottles and tubes	see Table 1
Nominal dimensions of largest bottle	.69 × 160 mm
Nominal bottle capacity	500 mL
Nominal rotor capacity	3 liters
Approximate acceleration time to maximum speed (rotor fully loaded)	4 1/2 min
Approximate deceleration time from maximum speed (rotor fully loaded, max. brake)	5 min
Weight of fully loaded rotor	22 kg (48 lb)
Rotor material	aluminum
Conditions requiring speed reduction	see RUN SPEEDS
Rotor entry code for Avanti J-E and microprocessor- controlled J2 and J6 centrifuges	10

\* The critical speed range is the range of speeds over which the rotor shifts so as to rotate about its center of mass. Passing through the critical speed range is characterized by some vibration.

† Relative Centrifugal Field (RCF) is the ratio of the centrifugal acceleration at a specified radius and speed ( $r\omega^2$ ) to the standard acceleration of gravity ( $g$ ) according to the following formula:

$$\text{RCF} = \frac{r\omega^2}{g}$$

where  $r$  is the radius in millimeters,  $\omega$  is the angular velocity in radians per second ( $2\pi \text{ RPM} / 60$ ), and  $g$  is the standard acceleration of gravity ( $9807 \text{ mm/s}^2$ ). After substitution:

$$\text{RCF} = 1.12 r \left( \frac{\text{RPM}}{1000} \right)^2$$

## DESCRIPTION

*This rotor has been manufactured in a registered ISO 9001 or 13485 facility for use with the specified Beckman Coulter centrifuges.*

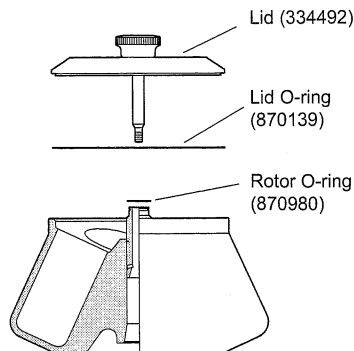

The JA-10 fixed angle rotor, rated for 10 000 rpm, is designed to centrifuge up to six 500-mL containers at a 25-degree angle to the axis of rotation. Used in Beckman Coulter J2, J6, and Avanti® J series centrifuges,<sup>1</sup> the rotor develops centrifugal forces that can efficiently pellet bacterial cells from large volumes, or particles from tissue homogenates. Up to 3 liters of sample and gradient can be centrifuged per run.

The rotor body and lid are made of aluminum and are anodized for corrosion resistance—the rotor is black and the lid is blue. The lid knob secures the rotor to the drive hub.

O-rings made of Buna N rubber in the lid and rotor body maintain atmospheric pressure inside the rotor during centrifugation, if they are properly lubricated. Pins in the rotor drive hole mate with grooves in the centrifuge drive hub (older model centrifuges), or with drive hub teeth (new model centrifuges), to prevent the rotor from slipping during acceleration and deceleration.

Starting in 2002, JA-10 rotors are manufactured with magnets embedded in the rotor base for rotor identification in the Avanti J-E centrifuge. Older JA-10 rotors without magnets can be used in the Avanti J-E, but the rotor speed will be limited to 6300 rpm. (Other Avanti J series and J2 series centrifuges use alternate methods of rotor identification that enable the rotor to run up to 10 000 rpm.)

The JA-10 rotor is warranted for 7 years (see the Warranty).

## PREPARATION AND USE

*Specific information about the JA-10 rotor is given here. Use the J Series Rotors and Tubes manual (JR-IM) along with this rotor manual for complete rotor and accessory operation.*

<sup>1</sup> Newer JA-10 rotors with magnets, p/n 369687, cannot be used in J2 or J6 series centrifuges. Older JA-10 rotors without magnets, p/n 334833, can be used in J2 and J6 series centrifuges.

**NOTE**

Although rotor components and accessories made by other manufacturers may fit in the JA-10 rotor, their safety in this rotor cannot be ascertained by Beckman Coulter. Use of other manufacturers' components or accessories in this rotor may void the rotor warranty and should be prohibited by your laboratory safety officer. Only the components and accessories listed in this publication should be used in this rotor.

**PRERUN SAFETY CHECKS**

*Read the Safety Notice page at the front of this manual before using the rotor.*

1. Make sure that the rotor and lid are clean and show no signs of corrosion or cracking.
2. Check the chemical compatibilities of all materials used (refer to Appendix A in *Rotors and Tubes*).
3. Verify that the tubes and bottles being used are listed in Table 1.

**ROTOR PREPARATION**

*For runs at other than room temperature, refrigerate or warm the rotor beforehand for fast temperature equilibration.*

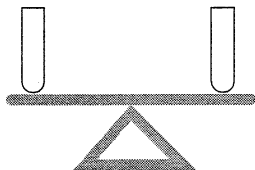

1. Apply a thin film of silicone vacuum grease (335148) to the O-rings.
2. Load the filled containers symmetrically into the rotor. (Refer to TUBES AND BOTTLES on page 6 for information about containers.) If fewer than six tubes are being run, they must be arranged symmetrically in the rotor (see Figure 1). Opposing tubes must be filled to the same level with liquid of the same density (within 10 grams).

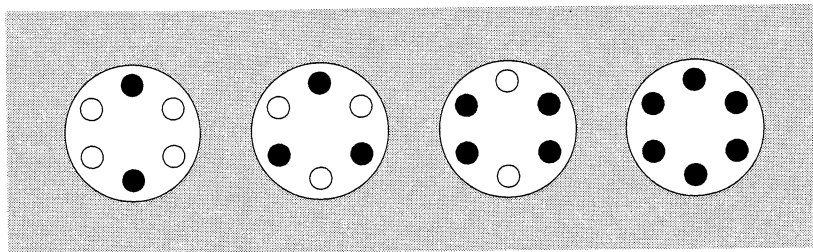

Figure 1. Arranging Tubes or Bottles in the Rotor.  
Two, three, four, or six tubes or bottles can be run,  
if they are arranged symmetrically in the rotor, as shown.

## TUBES AND BOTTLES

---

The JA-10 rotor uses the tubes and bottles listed in Table 1. Use only those items listed, and observe the maximum speed limits and fill volumes shown. (Maximum fill volume is the maximum amount that can be centrifuged in the container listed.) Refer to Appendix A in *Rotors and Tubes* for chemical compatibilities of tube, bottle, and accessory materials.

### Temperature Limits

---

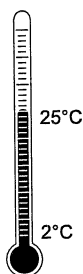

- Plastic containers have been centrifuge tested for use at temperatures between 2 and 25°C. For centrifugation at other temperatures, pretest tubes under anticipated run conditions.
- If plastic containers are frozen before use, make sure that they are thawed to at least 2°C prior to centrifugation.

### Thickwall Tubes

---



Thickwall polyallomer, polypropylene, and polycarbonate tubes can be run partially filled (at least half filled) with or without caps, but all opposing tubes for a run must be filled to the same level with liquid of the same density. Do not overfill capless tubes; be sure to note the fill volumes and run speeds shown in Table 1.

Table 1. Available Tubes and Bottles for the JA-10 Fixed Angle Rotor.  
Use only the items listed here and observe fill volumes and maximum run speeds.

Tube			Max Fill Vol <sup>a</sup> (mL)	Required Accessory		Max No. Tubes per Adapter	Max Speed <sup>b/</sup> RCF
Dimensions and Volume	Description	Part Number		Description	Part Number		
69 × 160 mm 500 mL	polycarbonate bottle w/cap assy	355605 (pkg/6)	465	none	—	—	10 000 rpm 17 700 × g
69 × 160 mm 500 mL	polypropylene bottle w/cap assy	355607 (pkg/6)	445	none	—	—	8 000 rpm 11 300 × g
62 × 120 mm 250 mL	polypropylene wide mouth bottle w/cap assy	356011 (pkg/6)	250	adapter, PET <sup>c</sup>	362750 (pkg/2)	1	10 000 rpm 17 700 × g
62 × 120 mm 250 mL	polycarbonate wide mouth bottle w/cap assy	356013 (pkg/6)	250	adapter, PET <sup>c</sup>	362750 (pkg/2)	1	10 000 rpm 17 700 × g
29 × 104 mm 50 mL	polycarbonate bottle assy w/liquid-tight cap assy	357000 (pkg/6)	45	adapter, polypropylene	356996 (pkg/1)	1	10 000 rpm 12 000 × g
29 × 104 mm 50 mL	polyallomer bottle assy w/liquid-tight cap assy	357001 (pkg/6)	45	adapter, polypropylene	356996 (pkg/1)	1	10 000 rpm 12 000 × g
29 × 104 mm 50 mL	polycarbonate bottle w/screw cap	357002 (pkg/25)	40	adapter, polypropylene	356996 (pkg/1)	1	10 000 rpm 12 000 × g
29 × 104 mm 50 mL	polyallomer bottle w/screw cap	357003 (pkg/25)	40	adapter, polypropylene	356996 (pkg/1)	1	10 000 rpm 12 000 × g
29 × 104 mm 50 mL	polypropylene thickwall tube w/snap-on cap	357005 (pkg/25)	36.5	adapter, polypropylene	356996 (pkg/1)	1	10 000 rpm 12 000 × g
				natural 29-mm cap red 29-mm cap green 29-mm cap yellow 29-mm cap blue 29-mm cap	356264 <sup>d</sup> 357359 <sup>d</sup> 357360 <sup>d</sup> 357361 <sup>d</sup> 357362 <sup>d</sup>		

<sup>a</sup> Above 20°C fill polypropylene tubes at least half full.

<sup>b</sup> Maximum speeds listed are guidelines only. These speeds have been achieved in reliability tests at Beckman Coulter, but, because of manufacturing variances, no guarantee of performance or fit is expressed or implied.

<sup>c</sup> Polyethylene terephthalate.

<sup>d</sup> Polypropylene; package of 25.

<sup>e</sup> Delrin is a registered trademark of E.I. Du Pont de Nemours & Company.

<sup>f</sup> Commercially available. Observe manufacturer's speed and fill volume guidelines.

— Continued

Table 1. Available Tubes and Bottles for the JA-10 Fixed Angle Rotor (continued)

Tube			Max Fill Vol <sup>a</sup> (mL)	Required Accessory		Max No. Tubes per Adapter	Max Speed <sup>b/</sup> RCF
Dimensions and Volume	Description	Part Number		Description	Part Number		
29 × 104 mm 50 mL	polypropylene thickwall tube, no cap	357007 (pkg/25)	50	adapter, polypropylene	356996 (pkg/1)	1	10 000 rpm 12 000 × g
29 × 104 mm 50 mL	polycarbonate open-top tube	363647 (pkg/25)	40	adapter, polypropylene	356996 (pkg/1)	1	10 000 rpm 12 000 × g
29 × 104 mm 50 mL	polycarbonate tube w/snap-on cap	363664 (pkg/25)	40	adapter, polypropylene	356996 (pkg/1)	1	10 000 rpm 12 000 × g
29 × 115 mm 50 mL	conical tube	f	f	adapter, polypropylene	356965 (pkg/1)	1	10 000 rpm 12 000 × g
17 × 120 mm 15 mL	conical tube	f	f	adapter, polypropylene	356960 (pkg/1)	5	6 500 rpm 7 000 × g
17 × 120 mm 15 mL	round-bottom tube	f	f	adapter, polypropylene	356994 (pkg/1)	5	10 000 rpm 12 000 × g
13 × 100 mm 7 mL	round-bottom tube	f	f	adapter, Delrin <sup>c</sup>	356973 (pkg/1)		10 000 12 000 × g
12 × 75 mm 4 mL	round-bottom tube	f	f	adapter, Delrin <sup>c</sup>	356967 (pkg/1)		10 000 12 000 × g
Bio-Vials 14 × 55 mm 4 mL	polypropylene, capped	566353 (pkg/1000)	4	adapter, Delrin <sup>c</sup>	342098 (pkg/1)	9	10 000 rpm
				adapter, PET <sup>c</sup>	362750 (pkg/2)	1	

<sup>a</sup> Above 20°C fill polypropylene tubes at least half full.

<sup>b</sup> Maximum speeds listed are guidelines only. These speeds have been achieved in reliability tests at Beckman Coulter, but, because of manufacturing variances, no guarantee of performance or fit is expressed or implied.

<sup>c</sup> Polyethylene terephthalate.

<sup>d</sup> Polypropylene; package of 25.

<sup>e</sup> Delrin is a registered trademark of E.I. Du Pont de Nemours & Company.

<sup>f</sup> Commercially available. Observe manufacturer's speed and fill volume guidelines.



### Polycarbonate and Polyallomer Bottles

Capped polycarbonate and polyallomer bottles may be run completely filled, or partially filled (not less than half full). All opposing containers for a run must be filled to the same level.



## OPERATION

---

### ROTOR ID

**JA-10**

- Precool the rotor in the centrifuge or in a refrigerator before use—especially before short runs—to ensure that the rotor reaches the set temperature. A suggested precooling cycle is a minimum of 30 minutes at 2000 rpm at the required temperature.
- If fluid containment is required, *use capped tubes or bottles*. It is strongly recommended that all containers carrying physiological fluids be capped to prevent leakage.
- *J2 and J6 series centrifuges only*. Apply a thin film of Spinkote™ lubricant (306812) to the centrifuge drive hub and to the metal threads on the lid knob.
- If you are using an Avanti J series centrifuge (except Avanti J-E), select the JA-10 rotor.
- If you are using an Avanti J-E or a microprocessor-controlled J2 or J6 series centrifuge, enter rotor code **10**.

## INSTALLING THE ROTOR

---

Lubricate J2 and J6 series centrifuge drive hubs with a thin, even coat of Spinkote (396812) to prevent the rotor from sticking. Avanti J series centrifuge hubs have Delrin<sup>2</sup> rings to prevent rotor sticking, and do not require lubrication.

Two metal pins inside the rotor drive hole engage with teeth on the centrifuge drive spindle hub to prevent the rotor from slipping during acceleration and deceleration (see Figure 2). When the rotor is properly installed, the pins sit either in the drive hub grooves or on top of the hub surface (see Figure 3).

The rotor pins are positioned parallel to the BECKMAN name engraved at the center of the rotor body (see Figure 4). Knowing the pin orientation before you install the rotor will help to ensure that you position the rotor properly on the hub, minimizing the chance of hub damage. Follow the steps below.

1. Turn the rotor until the BECKMAN name is either horizontal or perpendicular to the drive hub pins or teeth (see Figure 4). Alternately, rotate the drive spindle to align the hub pins or teeth with the rotor drive pins.

<sup>2</sup> Delrin is a registered trademark of E.I. Du Pont de Nemours & Company.

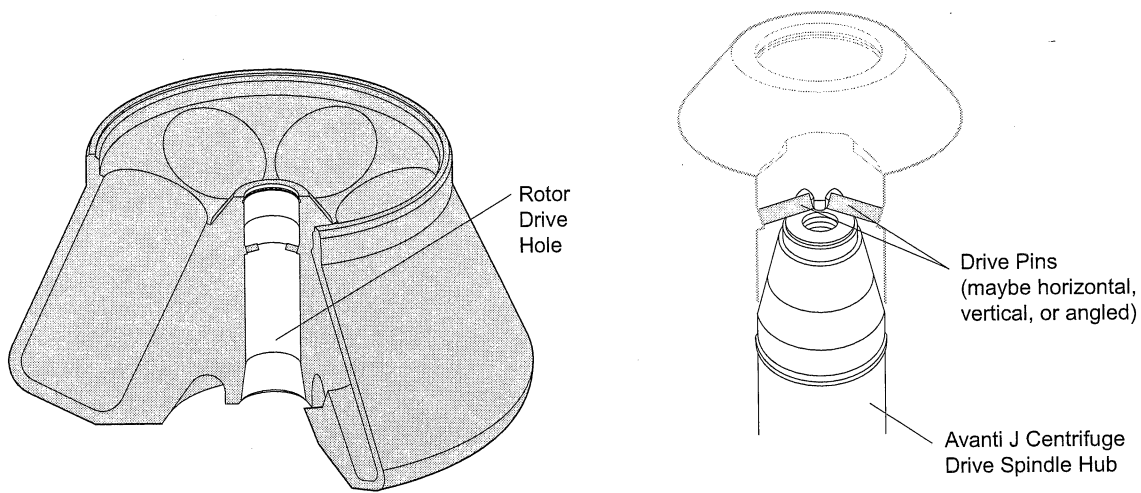

Figure 2. Rotor Drive Pin Location and Orientation

2. Carefully lower the rotor straight down onto the centrifuge drive spindle hub. *Do not drop the rotor onto the hub.*
3. Slowly turn the rotor, making sure that it is properly seated on the drive spindle hub. (In rare cases, the rotor pins can rest on top of the hub pins or teeth and not seat on the hub surface. This can prevent the rotor from being secured to the drive spindle. Turning the rotor slightly after installing it will move the pins into proper position.)

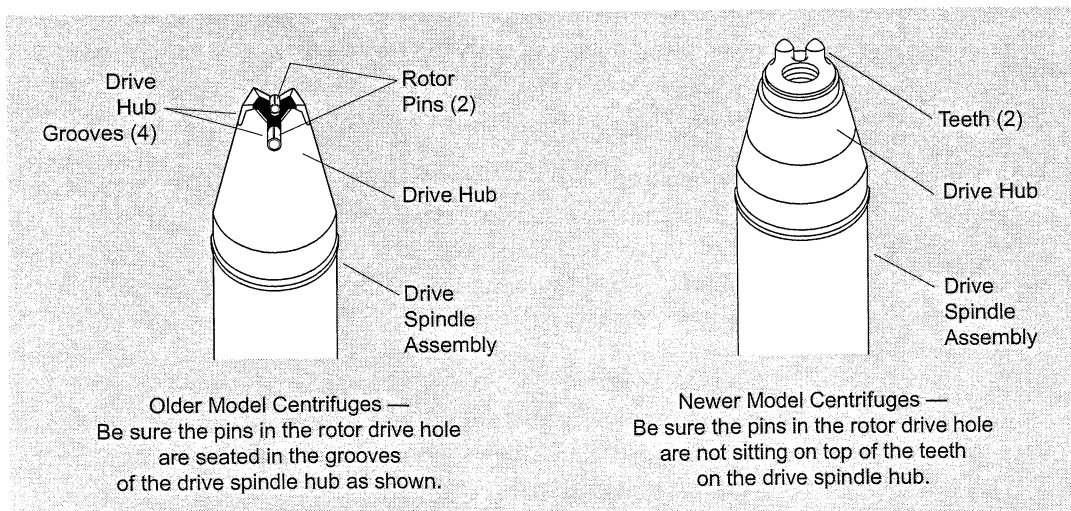

Figure 3. Centrifuge Drive Spindle Hub Configurations

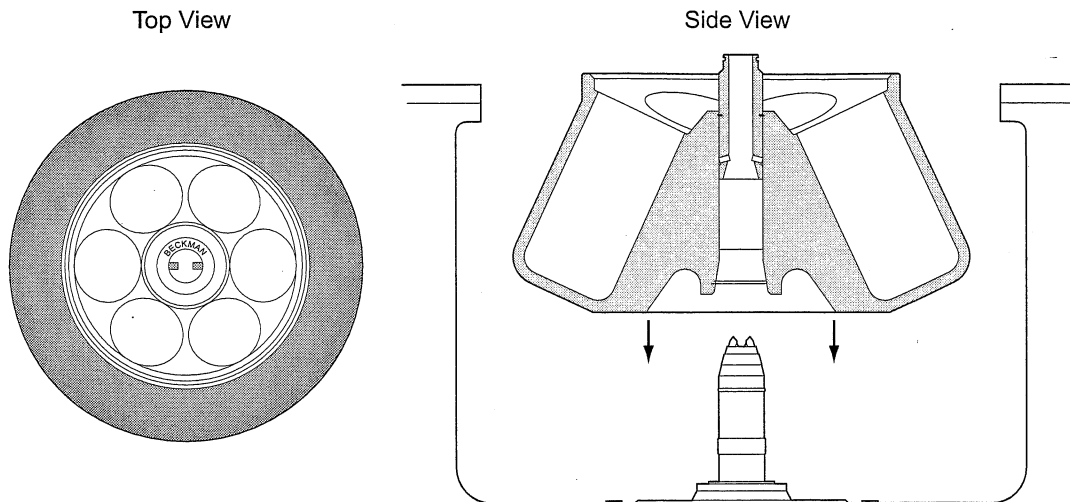

Figure 4. Installing the Rotor

4. To secure the rotor to the drive spindle, place the lid on the rotor and turn the lid knob to the right (clockwise) until secure. Do not overtighten.

## REMOVAL AND SAMPLE RECOVERY

---



### CAUTION

*If disassembly reveals evidence of leakage, you should assume that some fluid escaped the rotor. Apply appropriate decontamination procedures to the centrifuge and accessories.*

---

1. Unscrew the rotor lid to release the rotor from the spindle hub.
2. Remove the rotor by lifting it straight up and off the drive spindle. If the rotor sticks to the drive spindle hub, use the rotor removal tool (334827) to release the rotor as follows.
  - a. Screw the threaded end of the rotor removal tool into the rotor drive hole.
  - b. When the removal tool contacts the drive spindle hub, continue turning the removal tool until the rotor releases.
  - c. Unscrew and remove the removal tool from the rotor. The rotor should now lift easily off of the drive spindle hub.

## TEMPERATURE

---

TEMP °C

4

To ensure that the JA-10 rotor reaches the required temperature during the run, follow the appropriate instructions below for the model of J centrifuge being used.

### Avanti J Series Centrifuges

---

Enter the run temperature according to the instructions in your centrifuge instruction manual. No additional input is required.

### Microprocessor-Controlled J2 and J6 Series Centrifuges (Models J2-MI, J6-MI, J2-MC, and J6-MC)

---

Enter rotor code **10**, then follow the steps below.

1. Press the [TEMP] key on the centrifuge control panel and then use the keypad to enter the sample temperature.
2. Find the compensation value in Table 2 that corresponds with the set temperature and run speed. The compensation values listed in Table 2 are approximates for all centrifuge models. If precise temperature control is required, determine the compensation settings empirically as follows:
  - a. Fill the rotor with water-filled tubes or bottles. Precool the rotor and water to the required temperature.
  - b. Place the filled, precooled rotor in the centrifuge and run the system for at least 1/2 hour.
  - c. Measure the water temperature. If it is lower than the required run temperature, enter positive compensation units during run setup following steps 3 and 4 below. If it is higher than the required run temperature, enter negative compensation units during run setup, also using steps 3 and 4, below.
  - d. Discard the water. Fill tubes with sample, load tubes into the rotor, and precool the system to the required temperature before starting the run.
3. Press [COMP ADJ]. The word "COMP" flashes below the TEMPERATURE display and the display flashes.

4. Use the keypad to enter the desired compensation value. Press the [ $\pm$ .] key to enter a minus sign; pressing it again will remove the minus sign.
5. Check the temperature display. (If the entry is incorrect, press [CE] and reenter the digits.)
6. When the entry is correct, press [ENTER/RECALL].

**NOTE**

To clear a COMP ADJ entry, press [COMP ADJ], [0], and [ENTER/RECALL].

**Analog J2 Series Centrifuges**

Enter the required run temperature and the appropriate temperature compensation units (see Table 2) on the centrifuge control panel as follows.

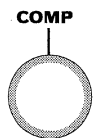
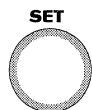

1. Turn the SET knob to the required sample temperature.
2. Find the compensation value that corresponds to the required temperature and run speed. The compensation values listed in Table 2 are approximate for all centrifuge models. If precise temperature control is required, follow the steps in **Microprocessor-Controlled J2 and J6 Series Centrifuges**, above.

*Table 2. Temperature Compensation Settings for J2 and J6 Series Centrifuges. Interpolate if intermediate values are required.*

Rotor Speed (rpm)	Required Sample Temperature ( $^{\circ}$ C, green bar)						
	$-20^{\circ}$	$-10^{\circ}$	$2^{\circ}$	$5^{\circ}$	$10^{\circ}$	$20^{\circ}$	$40^{\circ}$
10 000	N*	-3	-2	-1	0	+1	+2
8 000	-3	-2	-1 <sup>†</sup>	-1 <sup>†</sup>	0	+1	+2
5 000	-2	0	0	0	0	+1	+2

\* "N" indicates that the rotor cannot achieve the required temperature at this speed.

<sup>†</sup> For the J2-HC centrifuge, use a setting of 0 instead of -1.

## RUN TIMES

TIME HR:MIN

03:30

The  $k$  factor of the rotor is a measure of the rotor's pelleting efficiency. Beckman Coulter has calculated the  $k$  factors for all of its rotors, at maximum speed with full tubes, using the following formula:

$$k = \frac{\ln(r_{\max}/r_{\min})}{\omega^2} \times \frac{10^{13}}{3600} \quad (1)$$

where  $\omega$  is the angular velocity of the rotor in radians per second ( $\omega = 0.105 \times \text{rpm}$ ),  $r_{\max}$  is the maximum radius, and  $r_{\min}$  is the minimum radius.

After substitution:

$$k = \frac{(2.533 \times 10^{11}) \ln(r_{\max}/r_{\min})}{\text{rpm}^2} \quad (2)$$

In the JA-10 rotor, the  $k$  factor is 3610 for full 500-mL bottles at maximum speed.<sup>3</sup> For containers that nominally hold less than 500 mL, the  $k$  factors will be different. Calculate the  $k$  factors for these containers using equation (2).

Use the  $k$  factor in the following equation to estimate the run time  $t$  (in hours) required to pellet particles of known sedimentation coefficient  $s$  (in Svedberg units,  $S$ ).

$$t = \frac{k}{s} \quad (3)$$

For example, at 10 000 rpm *E. coli* ( $s = 3600 S$ ) will pellet in

$$t = \frac{3610}{3600} \approx 1 \text{ hour} \quad (4)$$

Run times can be estimated for centrifugation at less than maximum speed by adjusting the  $k$  factor as follows:

$$k_{\text{adj}} = k_{\text{rated}} \left( \frac{10\,000}{\text{actual run speed}} \right)^2 \quad (5)$$

<sup>3</sup> Based on sedimentation in water at 20°C.

Run times can also be estimated from data established in prior experiments using a different rotor if the  $k$  factor of the previous rotor is known. For any two rotors, a and b,

$$\frac{t_a}{t_b} = \frac{k_a}{k_b} \quad (6)$$

where the  $k$  factors have been adjusted for the actual run speed used.

For more information on  $k$  factors, see *Use of  $k$  Factor for Estimating Run Times from Previously Established Run Conditions* (publication DS-719).

## RUN SPEEDS

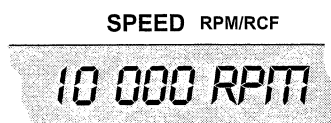

The centrifugal force at a given radius in a rotor is a function of speed. Comparisons of forces between different rotors are made by comparing the rotors' relative centrifugal fields (RCF). When rotational speed is adjusted so that identical samples are subjected to the same rcf in two different rotors, the samples are subjected to the same force. The RCF at a number of rotor speeds is provided in Table 3.

**Do not select rotational speeds higher than the maximums you have determined to be appropriate for your protocols (in no case above 10 000 rpm or the limit shown in Table 1).** In addition, when centrifuging solutions more dense than 1.2 g/mL in this rotor, calculate the reduced maximum allowable rotor speed:

$$\text{reduced maximum speed} = (10\,000 \text{ rpm}) \sqrt{\frac{1.2 \text{ g/mL}}{\text{density of tube contents}}} \quad (7)$$

*Note, however, that the use of this formula may still produce maximum speeds higher than the limitations imposed by the use of certain tubes or adapters (see Table 1).* In such cases, use the lower of the two figures.

Table 3. Relative Centrifugal Fields for the JA-10 Rotor.

Entries in this table are calculated from the formula

$$RCF = 1.12 r (RPM/1000)^2$$

and then rounded to three significant digits.

Rotor Speed (rpm)	Relative Centrifugal Field (x g)		
	At $r_{max}$ (158 mm)	At $r_{av}$ (98 mm)	At $r_{min}$ (38 mm)
10 000	17 700	11 000	4 260
9 500	16 000	9 910	3 840
9 000	14 300	8 890	3 450
8 500	12 800	7 930	3 070
8 000	11 300	7 020	2 720
7 500	9 950	6 170	2 390
7 000	8 670	5 380	2 090
6 500	7 480	4 640	1 800
6 000	6 370	3 950	1 530
5 500	5 350	3 320	1 290
5 000	4 420	2 740	1 060
4 500	3 580	2 220	861
4 000	2 830	1 760	680
3 500	2 170	1 340	521
3 000	1 590	987	383
2 500	1 110	686	266
2 000	707	439	170
1 500	398	246	95
1 000	176	109	42

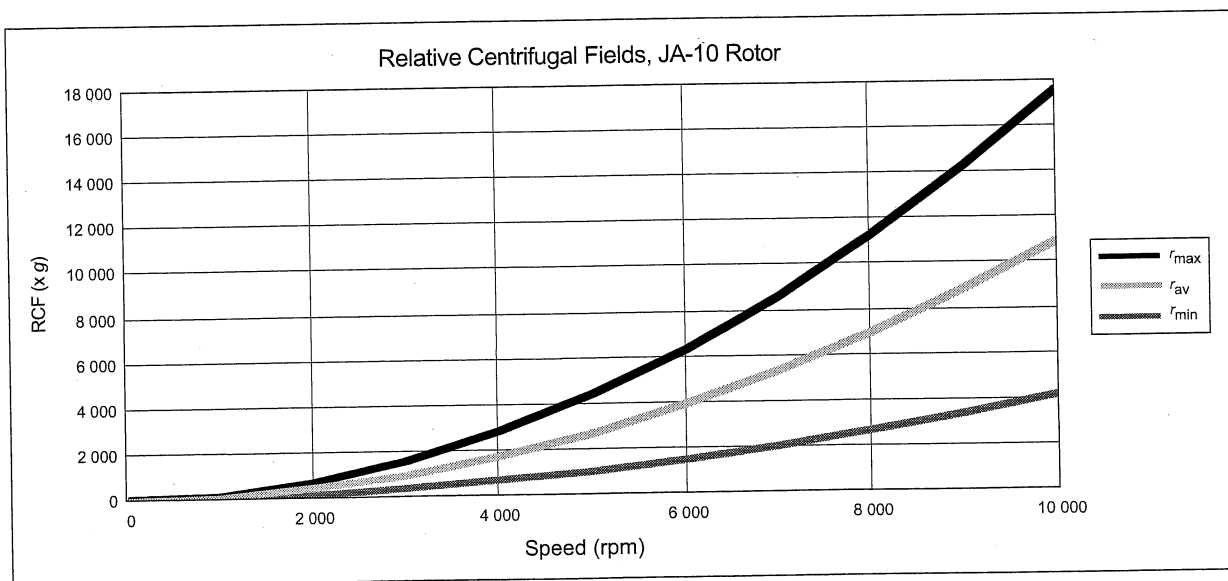



## CARE AND MAINTENANCE

### MAINTENANCE

#### NOTE

Do not use sharp tools on the rotor that could cause scratches in the rotor surface. Corrosion begins in scratches and may open fissures in the rotor with continued use.

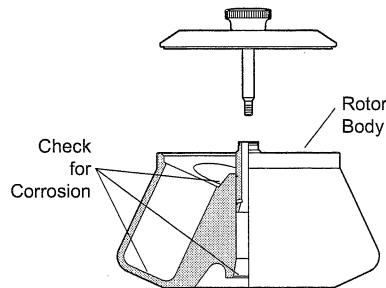

- Periodically (at least monthly) inspect the rotor, especially inside cavities, for rough spots or pitting, white powder deposits (frequently aluminum oxide), or heavy discoloration. If any of these signs are evident, do not run the rotor. Contact your Beckman Coulter representative for information about the Field Rotor Inspection Program and the rotor repair center.
- Before using the rotor, inspect the rotor drive pins to ensure that they are not damaged. Damaged drive pins can prevent the rotor from seating properly on the centrifuge drive hub (Avanti J series centrifuges only). To inspect the drive pins, turn the rotor upside down and look into the drive hole in the center of the rotor. If the drive pins appear damaged, contact Beckman Coulter Field Service.
- Regularly lubricate the metal threads in the rotor with a thin, even coat of Spinkote lubricant (306812). Failure to keep these threads lubricated can result in damaged threads.
- Regularly apply silicone vacuum grease (335148) to the lid O-ring (870139) and rotor O-ring (870980). Replace O-rings about twice a year or whenever worn or damaged.
- Routinely apply Spinkote lubricant (306812) to the centrifuge drive spindle to prevent the rotor from sticking (not required on Avanti J series centrifuges).

Refer to Appendix A in *Rotors and Tubes* for chemical compatibilities of rotor and accessory materials. Your Beckman Coulter representative provides contact with the Field Rotor Inspection Program and the rotor repair center.

## CLEANING

---

*Wash the rotor and rotor components immediately if salts or other corrosive materials are used or if spillage has occurred. Do not allow corrosive materials to dry on the rotor.*

Under normal use, wash the rotor frequently (at least weekly) to prevent buildup of residues.

1. Remove the O-rings before washing.
2. Wash the rotor and lid in a mild detergent, such as Beckman Solution 555™ (339555), that won't damage the rotor. The Rotor Cleaning Kit (339558) contains two special plastic-coated brushes and two quarts of Solution 555 for use with rotors and accessories. Dilute the detergent 10 to 1 with water.

### NOTE

Do not wash rotor components in a dishwasher.  
Do not soak in detergent solution for long periods, such as overnight.

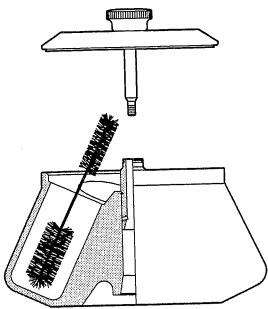

3. Thoroughly rinse the cleaned rotor and components with distilled water.
4. Air-dry the rotor and lid upside down. *Do not use acetone to dry the rotor.*
5. Apply a thin, even coat of silicone vacuum grease to the lid O-ring before replacing it in the groove in the outer rim of the lid. Also apply silicone vacuum grease to the rotor O-ring before reassembly.

Clean metal threads every 6 months, or as necessary. Use a brush and concentrated Solution 555. Rinse and dry thoroughly, then lubricate lightly but evenly with Spinkote to coat all threads.

Periodically remove the O-rings and wipe clean as necessary. Clean the O-ring grooves with a cotton-tipped swab. Reapply a light film of silicone vacuum grease.

## DECONTAMINATION

---



If the rotor (and/or accessories) becomes contaminated with radioactive material, it should be decontaminated using a solution that will not damage the anodized surfaces. Beckman Coulter has tested a number of solutions and found two that do not harm anodized aluminum: RadCon Surface Spray or IsoClean Solution (for soaking),<sup>4</sup> and Radiacwash.<sup>5</sup>

### NOTE

IsoClean can cause fading of colored anodized surfaces. Use it only when necessary and remove it promptly from surfaces.

While Beckman Coulter has tested these methods and found that they do not damage components, no guarantee of decontamination is expressed or implied. Consult your laboratory safety officer regarding the proper decontamination methods to use.



If the rotor or other components are contaminated with toxic or pathogenic materials, follow appropriate decontamination procedures as outlined by your laboratory safety officer.

## STERILIZATION AND DISINFECTION

---

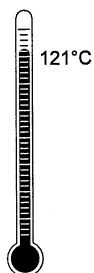

- The rotor and all rotor components can be autoclaved at 121°C for up to an hour. Remove the lid from the rotor and place the rotor and lid in the autoclave upside down.
- Ethanol (70%)<sup>6</sup> may be used on all rotor components, including those made of plastic. Bleach (sodium hypochlorite) may be used, but may cause discoloration of anodized surfaces. Use the minimum immersion time for each solution, per laboratory standards.

<sup>4</sup> In U.S., contact Nuclear Associates (New York); in Eastern Europe and Commonwealth States, contact Victoreen GmbH (Munich); in South Pacific, contact Gammasonics Pty. Ltd. (Australia); in Japan, contact Toyo Medic Co. Ltd. (Tokyo).

<sup>5</sup> In U.S., contact Biodex Medical Systems (Shirley, New York); internationally, contact the U.S. office to find the dealer closest to you.

<sup>6</sup> Flammability hazard. Do not use in or near operating centrifuges.

While Beckman Coulter has tested these methods and found that they do not damage the rotor or components, no guarantee of sterility or disinfection is expressed or implied. When sterilization or disinfection is a concern, consult your laboratory safety officer regarding proper methods to use.

Refer to publication IN-192, included in each box of tubes or bottles, for tube and bottle sterilization and disinfection procedures.

## **STORAGE**

---

When the rotor is not in use, store it in a dry environment (not in the instrument) with the lid removed to allow air circulation so moisture will not collect in the tube cavities.

## RETURNING A ROTOR

Before returning a rotor or accessory for any reason, prior permission (a Returned Goods Authorization form) must be obtained from Beckman Coulter, Inc. This RGA form may be obtained from your local Beckman Coulter sales office. It should contain the following information:

- serial number,
- history of use (approximate frequency of use),
- reason for the return,
- original purchase order number, billing number, and shipping number, if possible,
- name and phone number of the person to be notified upon receipt of the rotor or accessory at the factory, and
- name and phone number of the person to be notified about repair costs, etc.

To protect our personnel, it is the customer's responsibility to ensure that the parts are free from pathogens and/or radioactivity. Sterilization and decontamination must be done before returning the parts. Smaller items (such as tubes, bottles, etc.) should be enclosed in a sealed plastic bag.

*All parts must be accompanied by a note, plainly visible on the outside of the box or bag, stating that they are safe to handle and that they are not contaminated with pathogens or radioactivity. Failure to attach this notification will result in return or disposal of the items without review of the reported problem.*

Use the address label printed on the RGA form when mailing the rotor and/or accessories.

Customers located outside the United States should contact their local Beckman Coulter office.

## SUPPLY LIST

### NOTE

Publications referenced in this manual can be obtained by calling Beckman Coulter at 1-800-742-2345 in the United States, or by contacting your local Beckman Coulter office.

Contact Beckman Coulter Sales (1-800-742-2345 in the United States) or your local Beckman Coulter office, or see the *Beckman Coulter High Performance, High Speed, High Capacity Rotors, Tubes, and Accessories* catalog (BR-8102, available at [www.beckmancoulter.com](http://www.beckmancoulter.com)) for detailed information on ordering parts and supplies. For your convenience, a partial list is given below.

### REPLACEMENT ROTOR PARTS

JA-10 rotor assembly with magnets (rotors manufactured Jan. 2002 and later; <i>cannot</i> be used in J2/J6 series) . . . . .	369687
JA-10 rotor assembly (rotors manufactured through Dec. 2001) . . . . .	334833
Lid assembly . . . . .	392122
Lid O-ring (large) . . . . .	870139
Rotor O-ring (small) . . . . .	811656
Tie-down kit . . . . .	364911

### OTHER

Tubes, bottles, and accessories . . . . .	see Table 1
Spinkote lubricant (2 oz) . . . . .	306812
Silicone vacuum grease (1 oz) . . . . .	335148
Rotor Cleaning Kit . . . . .	339558
Beckman Solution 555 (1 qt) . . . . .	339555
Rotor cleaning brush . . . . .	339379
Rotor removal tool . . . . .	334827

---

## J SERIES ROTOR WARRANTY

Subject to the conditions specified below and the warranty clause of the Beckman Coulter, Inc., terms and conditions of sale in effect at the time of sale, Beckman Coulter, Inc. agrees to correct either by repair, or, at its election, by replacement, any defects of material or workmanship which develop within seven (7) years after delivery of a J series rotor to the original buyer by Beckman Coulter, Inc. or by an authorized representative, provided that investigation and factory inspection by Beckman Coulter, Inc. discloses that such defect developed under normal and proper use. Should a Beckman Coulter centrifuge be damaged due to a failure of a rotor covered by this warranty, Beckman Coulter will supply free of charge all centrifuge parts required for repair.

### REPLACEMENT

Any product claimed to be defective must, if requested by Beckman Coulter, Inc., be returned to the factory, transportation charges prepaid, and will be returned to Buyer with the transportation charges collect unless the product is found to be defective, in which case Beckman Coulter, Inc. will pay all transportation charges.

A defective rotor will be replaced by Beckman Coulter, Inc. at its then current list price less a credit based upon the age of the rotor (years since date of purchase). The Buyer shall not receive credit until the claimed defective rotor is returned to Beckman Coulter's Palo Alto, California, facility or delivered to a Beckman Field Service representative.

The replacement price (cost to Buyer) for the respective rotor shall be calculated as follows:

$$\text{Replacement price} = \text{Current rotor list price} \times \frac{\text{years}}{7}$$

### CONDITIONS

1. Except as otherwise specifically provided herein, this warranty covers the rotor only and Beckman Coulter, Inc. shall not be liable for damage to accessories or ancillary supplies including but not limited to (i) tubes, (ii) tube caps, (iii) tube adapters, or (iv) tube contents.
2. This warranty is void if the rotor has been subjected to customer misuse such as operation or maintenance contrary to the instructions in the Beckman Coulter rotor or centrifuge manual.
3. This warranty is void if the rotor is operated with a rotor drive unit or in a centrifuge unmatched to the rotor characteristics, or is operated in a Beckman Coulter centrifuge that has been improperly disassembled, repaired, or modified.

### DISCLAIMER

IT IS EXPRESSLY AGREED THAT THE ABOVE WARRANTY SHALL BE IN LIEU OF ALL WARRANTIES OF FITNESS AND OF THE WARRANTY OF MERCHANTABILITY AND THAT BECKMAN COULTER, INC. SHALL HAVE NO LIABILITY FOR SPECIAL OR CONSEQUENTIAL DAMAGES OF ANY KIND WHATSOEVER ARISING OUT OF THE MANUFACTURE, USE, SALE, HANDLING, REPAIR, MAINTENANCE, OR REPLACEMENT OF THE PRODUCT.

---

# Beckman Coulter Worldwide Biomedical Research Division Offices

## AUSTRALIA

Beckman Coulter Australia Pty Ltd  
Unit D, 24 College St.  
Gladesville, NSW 2111  
Australia  
Telephone: (61) 2 9844-6000  
or toll free: 1 800 060 880  
Fax: (61) 2 9844-6096  
email: lifescienceaustralia@beckman.com

## CANADA

Beckman Coulter (Canada) Inc.  
6755 Mississauga Road, Suite 600  
Mississauga, Ontario  
Canada L5N 7Y2  
Telephone: (1) 905 819-1234  
Fax: (1) 905 819-1485

## CHINA

Beckman Coulter Inc.  
Beijing Representative Office  
Unit 2005A, 2006-2009, East Ocean Center  
Jian Guomenwai Avenue  
Beijing 100004  
China  
Telephone: (86) 10 6515 6028  
Fax: (86) 10 6515 6025, 6515 6026

## CZECH REPUBLIC

Beckman Coulter Prague  
Radiova 1  
102 27 Prague 10  
Czech Republic  
Telephone: (420) 267 00 85 13  
Fax: (420) 267 00 83 23

## EASTERN EUROPE/ MIDDLE EAST/NORTH AFRICA

Beckman Coulter International S.A.  
22, Rue Juste-Olivier  
Case Postale 301-303  
CH-1260 Nyon, Switzerland  
Telephone: (41) 22 365 3707  
Fax: (41) 22 365 0700

## FRANCE

Beckman Coulter France S.A.  
Paris Nord II, 33/66 rue des Vanesses  
B.P. 50359  
Villepinte, France  
95942 ROISSY CDG Cedex  
Telephone: (33) 1 49 90 90 00  
Fax: (33) 1 49 90 90 10  
e-mail: bioresearch.france@beckman.com

## GERMANY

Beckman Coulter GmbH  
Europark Fichtenhain B-13  
47807 Krefeld  
Germany  
Telephone: (49) 21 51 33 35  
Fax: (49) 21 51 33 33  
e-mail: bioresearch.de@beckman.com

## HONG KONG

Beckman Coulter Hong Kong Ltd.  
12th Floor, Oxford House  
979 King's Road  
Taikoo Place, Hong Kong  
Telephone: (852) 2814 7431  
Fax: (852) 2873 4511

## INDIA

Beckman Coulter India Pvt. Ltd.  
Solitaire Corporate Park  
3rd Floor - Bldg. 11  
Andheri Ghatkopar Link Road  
Chakala, Andheri West  
Mumbai India 400 098  
Telephone: (91) 22 3080 5101

## ITALY

Beckman Coulter S.p.a.  
Centro Direzionale Lombardo  
Palazzo F/1, Via Roma 108  
20060 Cassina de' Pecchi  
Milano, Italy  
Telephone: (39) 02 953921  
Fax: (39) 02 95392264

## JAPAN

Beckman Coulter K.K.  
TOC Ariake West Tower  
2-5-7, Ariake, Koto-ku  
Tokyo 135-0063 Japan  
Telephone: (81) 3 5530 8500  
Fax: (81) 3 5404 8436

## MEXICO

Beckman Coulter de Mexico S.A. de C.V.  
Avenida Popocatepetl #396  
Colonia Gral. Pedro Maria Anaya  
Codigo Postal 03340  
Mexico, D.F. Mexico  
Telephone: (001) 52-55-9183-2800

## NETHERLANDS

Beckman Coulter Nederland B.V.  
Nijverheidsweg 21  
3641 RP-Mijdrecht  
Postbus 47  
3640 AA Mijdrecht  
The Netherlands  
Telephone: (31) 297-230630  
Fax: (31) 297-288082

## SINGAPORE

Beckman Coulter Singapore Pte. Ltd.  
116 Changi Road  
Unit #03-01/02  
Singapore 419718  
Telephone: (65) 6339 3633  
Fax: (65) 6336 6303

## SOUTH AFRICA/SUB-SAHARAN AFRICA

Beckman Coulter  
Stand 1A Primegro Park  
Tonetti Street  
1685 Halfway House  
Johannesburg  
Republic of South Africa  
Telephone: (27) 11-805-2014/5  
Fax: (27) 11-805-4120  
e-mail: beckman@intekom.co.za

## SPAIN

Beckman Coulter España S.A.  
C/ Caleruega, 81  
28033 Madrid, Spain  
Telephone: (34) 91 3836080  
Fax: (34) 91 3836096  
email: bioresearch.espana@beckman.com

## SWEDEN

Beckman Coulter AB  
Archimedesvaegen 7  
Box 111 56  
SE-168 11 Bromma  
Sweden  
Telephone: (46) 8 564 85 900  
Telefax: (46) 8 564 85 901

## SWITZERLAND

Beckman Coulter International S.A.  
22, Rue Juste-Olivier  
Case Postale 301-303  
CH-1260 Nyon  
Switzerland  
Telephone: (41) 0800 850 810  
Fax: (41) 0848 850 810

## TAIWAN

Beckman Coulter Taiwan Inc.  
Taiwan Branch  
8th Floor  
216 Tun Hwa South Road, Section 2  
Taipei 106, Taiwan  
Republic of China  
Telephone: (886) 2 2378 3456  
Fax: (886) 2 2377 0408

## TURKEY

Beckman Coulter Ltd.  
E-5 Yanyol Faith Cad.  
81410 Soganlik Kartal  
Istanbul  
Turkey  
Telephone: (90) 216 309 1900  
Fax: (90) 216 309 0090

## UNITED KINGDOM

Beckman Coulter United Kingdom Ltd  
Oakley Court  
Kingsmead Business Park  
London Road  
High Wycombe  
Buckinghamshire HP11 1JU  
England, U.K.  
Telephone: (44) 01494 441181  
Fax: (44) 01494 447558  
e-mail: beckman\_uk@beckman.com

*Additional addresses are available at  
www.beckmancoulter.com.*



Beckman Coulter, Inc. • 4300 N. Harbor Boulevard, Box 3100 • Fullerton, California 92834-3100  
Sales and Service: 1-800-742-2345 • Internet: www.beckmancoulter.com • Telex: 678413 • Fax: 1-800-643-4366

